

# LWGY Turbine Flowmeter





## Introduction

LWGY turbine flow meter consists of turbine flow sensor and display instrument and it is made by us using foreign state-of-the-art technologies, which is an ideal gauge for measuring of liquid flow.

The flow meter is characterized by simple structure, high precision and easy installation and repair.

It is applicable in closed pipes to measure flow of liquid which will not erode stainless steel (1Cr18Ni9Ti), 2Cr13, Al<sub>2</sub>O<sub>3</sub> and hard alloy and is free of impurities such as fiber and granules. if this product is used in association with display instruments with special functions, it can be used for purpose of automatic definite quantity control and alarming in case of excessive amount.



## Working Principle

When liquid flows through the sensor, the impulse of fluid will provide the blade with a rotation moment as there is an angle between the blade of impeller and the flow direction. the blade will rotate as the friction moment and the fluid resistance are overcome and it will reach a stable speed when the moments are at balance. under certain conditions, the rotation speed of blade will be in direct proportion to the flow velocity. due to the magnetic conductivity of blade, when located in the magnetic field generated by signal detector (made of permanent magnet steel and coils), the rotating blade will cut the magnetic lines and periodically change the flux through the coil, thereby inducing electrical impulse signals at both ends of the coil. the induced signals, after amplified and rectified by amplifier, will form a continuous rectangular impulse wave with certain amplitude which may be remotely transmitted to display instrument indicating the instant flow and the cumulative flow of fluid. within a certain range of flow, the impulse frequency is in direct proportion to the instant flow of fluid flowing through the sensor, which is shown in the equation below:

### Wherein:

f	Impulse frequency [Hz].
k	Instrument factor of sensor [1/m <sup>3</sup> ], which is given by checklist. [1/L] is used as the unit, the equation will be.
Q	Instant flow of liquid (in operation) [m <sup>3</sup> /h].
3600	Conversion factor.

## LWGY Turbine Flow Meter

Instrument factor of each sensor will be filled out in verification certificate by the manufacturer. The instant flow and cumulative flow will be displayed when the value of k is loaded into associated display instrument.

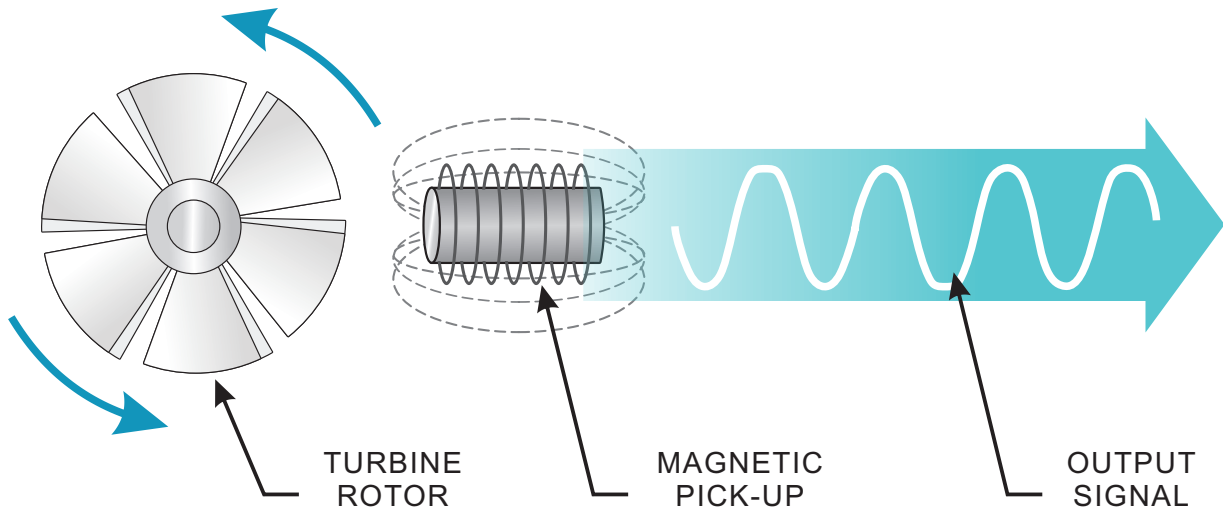

## Application

The product can be used in a wide range of industries, including oil industry, chemical industry, metallurgy, water supply, paper-making, environment protection and food industry.

- Flow measurement of tap water, demineralised water and chemicals.
- Fuels, marine engine fuel monitoring, vegetable oil, thermal oil and solvents.
- Special models for refrigerants, pharmaceutical fluids, cryogenic fluids.
- Liquefied gases and high-pressure applications.





## Product Features

- Hard alloy bearing thrust type sensor, guarantee precision, improve wear resistance performance.
- Simple and firm structure, easy to install and disassemble.
- Wide measuring range, low flow velocity workable.
- Small pressure loss, fine repeat ability, high precision.
- High resistance to electromagnetic interference



## LCD Display

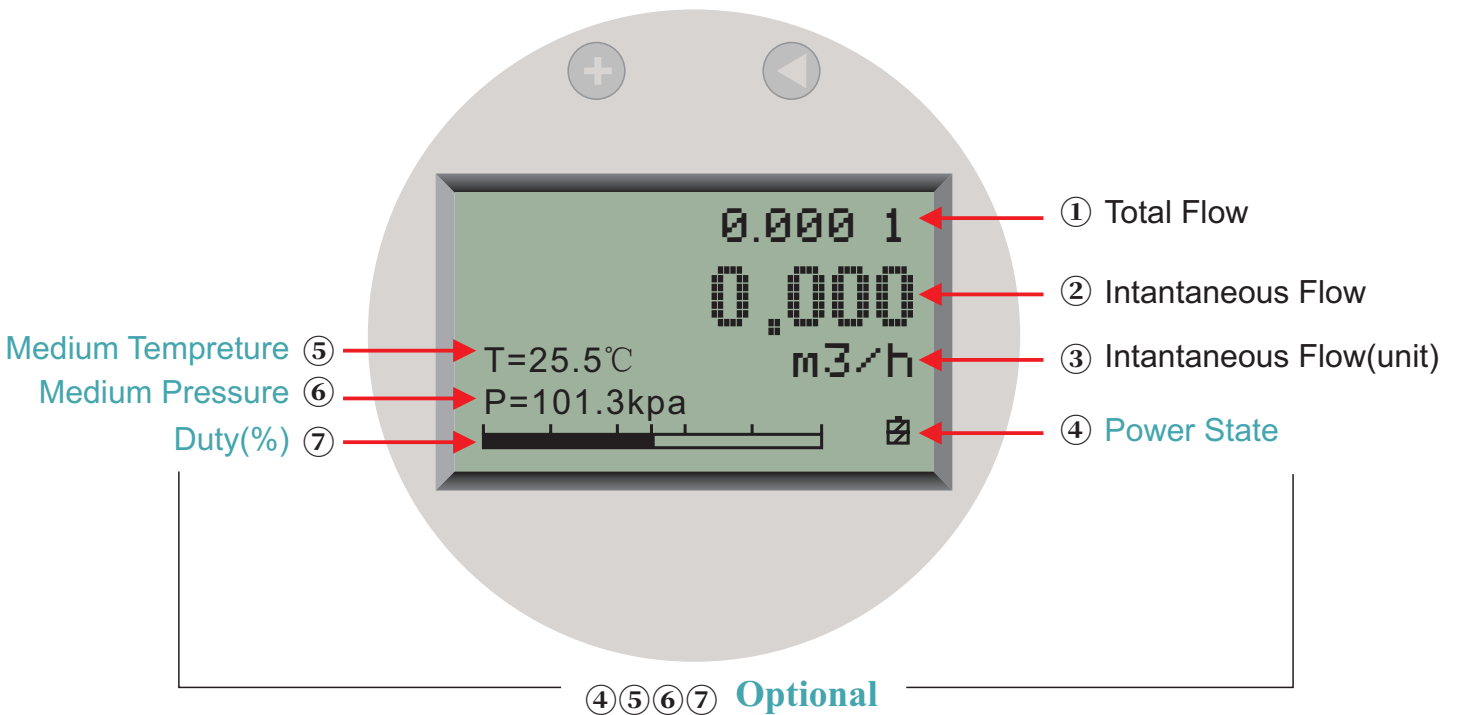

- Low-Power Design LCD
- Multi-unit free switching, on-site display and analysis

**Flow Unit:** L, gallon, m<sup>3</sup>, kg, pound, ton, etc

**Time Unit:** Hour and Minute



### Different Structure



### Different Connection for Compact Type With LCD Display





## Technical Performance Parameters

Size & Process Connection	Thread connection:DN4, 6, 10, 15, 20, 32, 40, 50, 65, 80, 100 Flange connection:DN15, 20, 32, 40, 50, 65, 80, 100, 125, 200 Clamp connection:DN4, 6, 10, 15, 20, 32, 40, 50, 65, 80, 100
Accuracy	±0.5%, ±0.2% Optional
Sensor Material	SS304, SS316L Optional
Impeller	2Cr13
Temperature	Medium temperature: -20℃~+80℃ standard -20℃~+150℃ Ambient temperature: -20℃~+60℃
Signal Output	Pulse, 4-20mA, Alarm(optional)
Digital Communication	RS485 MODBUS RUT, HART
Power Supply	24V DC/3.6V Lithium Battery
Cable Entry	M20*1.5; 1/2"NPT
Explosion-proof class	Ex d IIC T6 Gb
Protection class	IP65; IP67 Optional
Structure	Compact, Remote
Cable length	10m standard, other length optional



## Size- Flow Range- Connection

Size	Standard Flow Range (m <sup>3</sup> /h)	Extended Flow Range(m <sup>3</sup> /h)	Common Connection & Pressure	Customized Pressure
DN4	0.04-0.25	0.04-0.4	Thread/6.3MPa	4-42MPa
DN6	0.1-0.6	0.06-0.6	Thread/6.3MPa	
DN10	0.2-1.2	0.15-1.5	Thread/6.3MPa	
DN15	0.6-6	0.4-8	Thread/6.3MPa	
			Flange/4.0MPa	
DN20	0.8-8	0.45-9	Thread/6.3MPa	
			Flange/4.0MPa	

# LWGY Turbine Flow Meter

DN25	1-10	0.5-10	Thread/6.3MPa	4-42MPa
			Flange/4.0MPa	
DN32	1.5-15	0.75-15	Thread/6.3MPa	
			Flange/4.0MPa	
DN40	2-20	1-20	Thread/6.3MPa	
			Flange/4.0MPa	
DN50	4-40	2-40	Thread/6.3MPa	
			Flange/4.0MPa	
DN65	7-70	3.5-70	Thread/1.6MPa	
			Flange/1.6MPa	
DN80	10-100	5-100	Thread/1.6MPa	
			Flange/1.6MPa	
DN100	20-200	10-200	Thread/1.6MPa	
			Flange/1.6MPa	
DN125	25-250	12.5-250	Flange/1.6MPa	
DN150	30-300	15-300	Flange/1.6MPa	
DN200	80-800	40-800	Flange/1.6MPa	



## Size

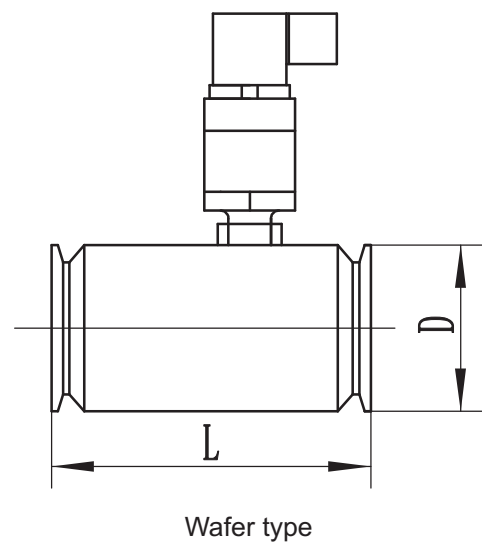
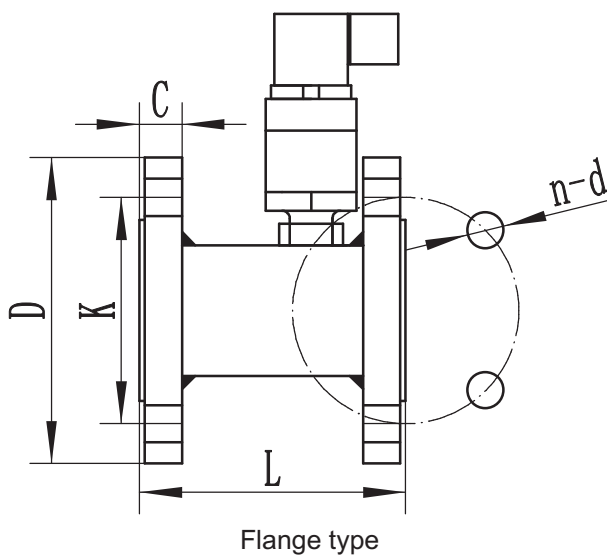

# LWGY Turbine Flow Meter

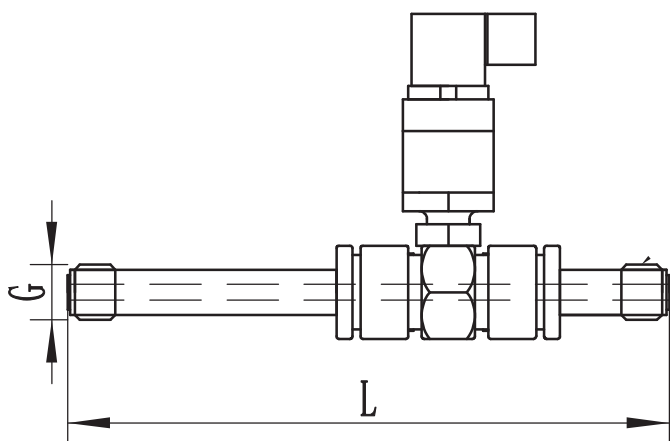

With straight pipeline

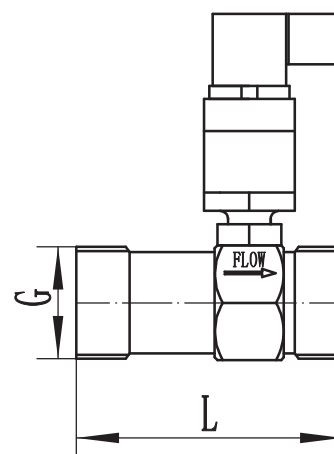

Thread connection type

DN(mm)	Flange Connection					Flange Thick C(mm)	Thread G(Male)	Tri-clamp Clamp OD(mm)	
	L(mm)	D(mm)	K(mm)	d(mm)	n (Hole Number)				
4	225							G½"	50.5
6	225							G½"	50.5
10	345	90	60	14	4	16	G½"	50.5	
15	75	95	65	14	4	16	G1"	50.5	
20	80	105	75	14	4	18	G1"	50.5	
25	100	115	85	14	4	18	G¼"	50.5	
32	120	140	100	18	4	18	G1½"	50.5	
40	140	150	110	18	4	19	G2"	64	
50	150	165	125	18	4	21	G2½"	77	
65	175	185	145	18	4	21	G3"	91	
80	200	200	160	18	8	23		106	
100	220	220	180	18	8	23		119	
125	250	250	210	18	8	25			
150	300	285	240	22	8	25			
200	360	340	295	22	12	27			
250	400	405	355	26	12	29			
300	450	460	410	26	12	32			



## Model Selection

LWGY		X	X	X	X	X	X	X	X	X	
Size	DN4-DN200										
Type	Flow sensor, pulse, three-wire, 12 VDC		A								
	Flow transmitter, 4~20 mA, 24 VDC		B								
	Local display, 3.6V battery		C								
	Local display, 4~20 mA, 24 VDC		D								
	Local display, HART, 24 VDC		E								
	Local display, RS485 MODBUS, 24 VDC		F								
Accuracy	±0.5% of reading				5						
	±0.2% of reading				2						
Flow	Standard				S						
	Extended				E						
Explosion Proof	Without					WT					
	With					W					
Body Material	SS304						4				
	SS316						6				
Temperature	-20°C~+80°C							S			
	-20°C~+150°C							H			
Structure	Compact								C		
	Remote								R		
Process Connection	Flange	DIN D10: PN10, D16: PN16, D25: PN25, D40: PN40								D**	
		ANSI A15: 150#, A30: 300#, A60: 600#								A**	
		JIS J10: 10K, J20: 20K, J30: 30K								J**	
		Others								O	
	Thread	Male								M	
		Female								F	
	Tri-clamp								C		
Wafer								W			



## Installation Notice

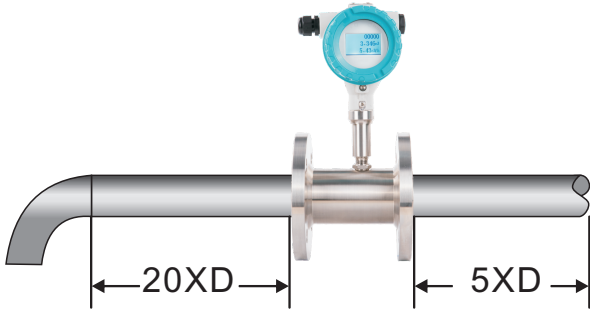

One 90° elbow

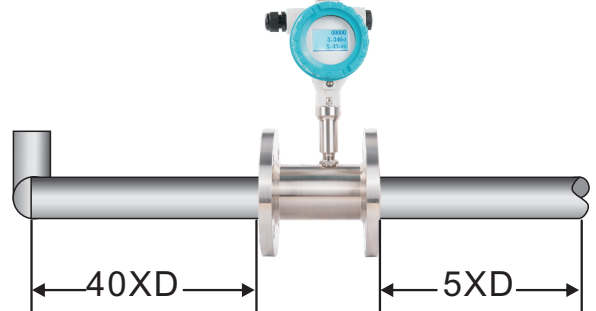

Two 90° elbows for two planes

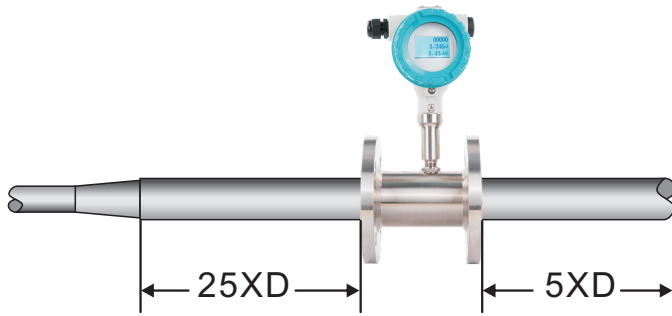

Concentric expander

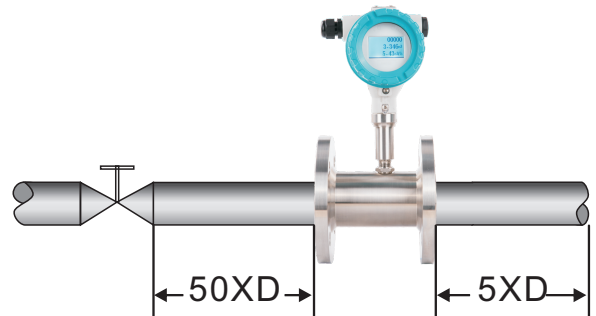

Control valve half-open

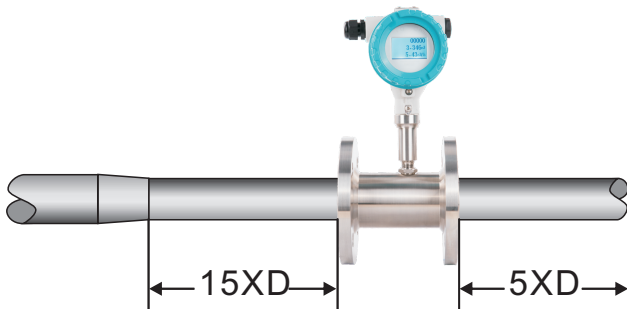

Concentric shrinkage wide open valve

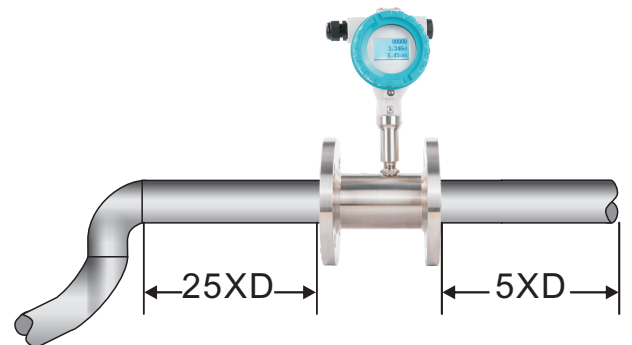

Two 90° elbows for one plane

Suggest all control valves are installed downstream of the flowmeter.



Representantes / Distribuidores Autorizados

Dastec Uruguay S.R.L.  
Tel: (+59 8) 2400 4046  
Email: [info@dastecsrl.com.uy](mailto:info@dastecsrl.com.uy)  
Web: [www.dastecsrl.com.uy](http://www.dastecsrl.com.uy)



Representantes / Distribuidores Autorizados

Dastec S.R.L. Paraguay  
Tel: (+595 9) 8310 0799  
Email: [info@dastecsrl.com.py](mailto:info@dastecsrl.com.py)  
Web: [www.dastecsrl.com.py](http://www.dastecsrl.com.py)